

CLIMIA

CTK 240 mobile air dehumidifier

Operating manual





Climia

CTK 240 mobile air dehumidifier

Contents

1.0 Safety instructions	4-10
2.0 Guarantee	10
3.0 Intended use	10
4.0 Environmental protection and recycling	10
5.0 Transport and packaging	10
6.0 Air dehumidification	11-13
7.0 Unit description	14
8.0 Set-up	15
9.0 Commissioning	15-18
10.0 Shutdown	18
11.0 Unit transport	18
12.0 Care and maintenance	19-20
13.0 Troubleshooting	20
14.0 Electrical wiring	21
15.0 Electrical wiring diagram	21
16.0 WiFi function	22
17.0 General view of unit	23
18.0 Spare parts list	24
19.0 Technical data	25
20.0 Maintenance log	26
EC Declaration of Conformity	27

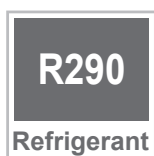

**Carefully read this operating manual prior to commissioning/using the units!
This operating manual is a translation of the German original.**

This manual is an integral part of the unit and must always be kept in the vicinity of the installation location or on the unit itself.

Subject to modifications; no liability accepted for errors or misprints!

1.0 Safety information

General safety notes

- Carefully read the manual before commissioning the units or their components for the first time. It provides useful tips and notes such as hazard warnings to prevent injury and material damage. Failure to follow the directions in this manual can endanger persons, the environment and the equipment itself or its components and will void any claims for liability.
- Store this manual and the information required for the operation of this system (e.g. refrigerant datasheet) in the vicinity of the units.
- This unit may only be installed and operated as described in this manual.
- Independent conversion and/or modification of any kind is strictly prohibited.
- National regulations in connection with installation must be observed.
- Children must not be left unsupervised when close to the unit.
- For safety reasons, people with mental, physical or other health limitations must not operate this unit unattended.
- The unit is not permitted to be operated with damaged cables. The unit must be repaired by a specialist immediately.
- The unit may only be operated via a power supply with grounding.
- The use of extension cables is not recommended.
- The air filter must be cleaned at intervals of no more than 2 weeks.
- The unit is not permitted to be operated in the vicinity of heat sources.
- The unit must be transported upright. Residue from the condensate must be drained off before transport. The unit must be stood upright for 1 hour prior to commissioning.
- Combustible substances and pressure containers must be kept at least 50 cm from the unit.
- The unit must not be stored and operated in rooms with oil, gas or sulphur.
- The unit must always be switched off with the on/off switch.
- Do not place anything on the device in particular heavy or hot objects.
- Repairs may only be carried out by authorised and certified specialist personnel.
- This unit must be disposed of professionally in accordance with environmental protection.
- The safety notes in regards to the room sizes and the flammability of the refrigerant must not be removed from the machine.
- The units may only be operated in well ventilated areas.
- The unit can be used by children 8 years and up and by persons without physical, mental or other health limitations if this knowledge has been obtained via the necessary safety notes..
- Children must never play with the unit.
- Cleaning the units must not be carried out by children without parental/guardian supervision.

The following notes must be observed in full:

- The units must not be operated at an ambient temperature below 5 °C.
- The units may not be set up or operated in explosive environments.
- The units must not be installed or operated in atmospheres containing oil, sulphur, chlorine, salt or dust.
- Never insert foreign objects into the units.
- The units may not be exposed to direct jets of water.
- An unobstructed air inlet and air outlet must be guaranteed at all times.
- The air-inlet grille must always be kept free of dirt and loose objects.
- The units must not be covered during operation.
- The units must be installed upright and in a stable position.

CTK 240 mobile air dehumidifier

- The units must not be transported while they are running.
- All electrical cables on the outside of the units must be protected against damage (e.g. by animals etc.).
- Before each change of location, the condensate containers must be emptied.
- Appropriate hazard prevention measures must be taken to prevent risks to people when performing installation, repair, maintenance or cleaning work on the units.
- The units and components should not be exposed to any mechanical load, extreme levels of humidity or direct exposure to sunlight.
- The units may only be operated in indoor areas.

Additional safety notes when handling refrigerant R290



Warning of inflammable substances !

- The refrigerant R290 fulfils the requirements of the European F-Gas regulation.
- The units contain 0.108 kg of refrigerant R290 depending on the unit type.
- The maximum permitted amount of refrigerant R290 is 0.3 kg.
- The units must not be burned, drilled or pierced.
- Only use cleaning agents which have been approved by the manufacturer for cleaning.
- The unit must never be operated in rooms with naked flames (e.g. gas heaters, open fireplaces, etc.).
- Refrigerant circuit components must not be deformed.
- The contained refrigerant R290 is colourless and odourless.

- The unit must not be stored or operated in rooms which have a room area of 5 m² or less.
- The accumulation of refrigerant due to leakages can lead to a fire and explosions in rooms which are too small due to the development of heat or ignition sources.
- The units must be stored carefully. Mechanical damage must be avoided.
- Intervention in the refrigeration circuit may only be done by certified specialist personnel taking into account the safety notes of the manufacturer.
- Maintenance and repairs may only be carried out by authorised personnel which have the corresponding knowledge in regards to flammable refrigerant.

WARNING!

Do not use anything other than the agent recommended by the manufacturer to speed up a possible defrosting process or to clean the units. The unit may only be operated and stored in rooms where there are no devices with potential ignition sources. Do not go below the minimum room area of 5 m². Note that leaking refrigerant is colourless and odourless. The unit must not be burned or pierced!

Safety instructions for the operator

The operational safety of the units and components is only assured providing they are used as intended and in a fully assembled state.

- This unit may only be installed and operated as described in this manual.
- Independent conversion and/or modification of any kind is strictly prohibited.
- Children must not be left unsupervised when close to the unit.
- For safety reasons, people with mental, physical or other health limitations must not operate this unit unattended.
- The unit is not permitted to be operated with damaged cables. The unit must be repaired by a specialist immediately.
- The unit may only be operated via a power supply with grounding.
- The use of extension cables is not recommended.
- The air filter must be cleaned at intervals of no more than 2 weeks.
- The unit is not permitted to be operated in the vicinity of heat sources.
- The unit must be transported upright. Residue from the condensate must be drained off before transport. The unit must be stood upright for 1 hour prior to commissioning.
- Operating the units in rooms with potential ignition sources (naked flames, gas or electrical heaters, fireplaces) is prohibited. Attach signs prohibiting smoking.
- The unit may only be installed, operated and stored in rooms larger than 5 m².
- Protective covers (grilles) over moving parts must not be removed from units that are in operation.
- Do not operate units or components with obvious defects or signs of damage.
- Contact with equipment parts or components can lead to burns or injury.
- The units and components must not be exposed to any mechanical load, extreme levels of humidity or extreme temperatures.
- Never drill through the housing cover or have the unit come into contact with fire.
- Rooms in which refrigerant may escape must be adequately aerated and ventilated. Otherwise there is danger of suffocation.
- All housing parts and unit openings, e.g. air inlets and outlets, must be free from foreign objects, fluids or gases.
- Do not leave the units running for an extended period unsupervised.

! Improper use can cause serious damage to the unit.
Read this manual carefully before commissioning!

CTK 240 mobile air dehumidifier

Do not allow children to play with the unit.



Never cover the air inlets and outlets.



Do not stand or sit on the unit.



Unplug the power plug when not in use for a long period.



Unplug the power plug before cleaning the unit.



Ensure the voltage is correct (220-240 V AC, 50 Hz).



Do not disassemble housing parts (consult a specialist company).



Do not operate the unit with defective cables or sockets.



The unit and in particular the control panel must not come into contact with water.



Safety notes for installation, maintenance and inspection

- **Check the work area**
Before starting work on units with combustible refrigerants, ensure that any potential ignition sources are removed and the risk of igniting the refrigerants is eliminated. The aforementioned safety notes for repairing the units must be observed at all times. Work may only be carried out by authorised specialist personnel with knowledge of handling combustible refrigerants!
- **Prepare the work area**
Any persons present must be informed about the repair process accordingly and persons not involved must vacate the work area. Working in rooms with limited space is prohibited. Ensure that sufficient space is available at the workplace. Ensure that the ambient conditions are suitable for working with combustible refrigerants.
- **Identify refrigerant leaks, check the atmosphere**
Refrigerant may unexpectedly escape when working on the refrigerant circuit. Ensure that the atmosphere in the workplace is not combustible at all times by using suitable refrigerant detectors. Be sure to ensure that the refrigerant detector used is suitable, approved and calibrated for use with refrigerant R290.
- **Provide fire extinguishers**
Provide appropriate fire extinguishers before starting work. For this purpose, dry powder or CO₂ fire extinguishers are suitable.

- **Remove any potential ignition sources**
Leaking refrigerant in combination with corresponding ignition sources can lead to an explosion. All ignition sources must therefore be kept away from the working area at all times! This also includes the smoking of cigarettes. Inform all persons present that this includes the affixing of safety notes and the closing off of the working area.
- **Sufficient ventilation**
Before starting work, ensure that the working area is outdoors or has sufficient ventilation. A continuous ventilation stream is required while working. The safety of the persons working must be guaranteed by the exhaust air equipment: potentially leaking refrigerant must be lead away safely and drained into the atmosphere in an optimum manner.
- **Checking the refrigerant circuit**
If electronic components need to be replaced, ensure that the spare parts have the same function and identical technical specifications. The maintenance and replacement regulations of the manufacturer must always be observed and complied with. Please contact the support of the manufacturer with any problems or queries. The following safety checks must be carried out when using combustible refrigerants:
 - The fill level adjusts to the size of the rooms in which the unit is located.
 - The exhaust air equipment and its outlets function properly and are not blocked or obstructed.
- **Checking the electronic components**
A component and safety check must be carried out before repairing and maintaining electronic components. If safety cannot be ensured due to a defect on a component, installation must not take place until safety can be guaranteed again. If the defect on the spare part cannot be remedied and downtime of the unit is no longer acceptable, an adequate temporary solution must be arranged. The owner/operator of the unit must be informed about this. The detailed safety check must include the following aspects:
 - Capacitors are discharged. Discharging must be done in a safe process to prevent flying sparks.
 - There must be no electronic components active or uninsulated wires while filling, repairing or cleaning.
 - There must be no earthing of the system.
- **Repairs to closed components**
Before repairing closed components/housing parts, the unit must be free from voltage. If carrying out the repairs free from voltage cannot be avoided, the critical points of potential refrigerant leakages must be checked using a leak detector. The following notes must be observed when working on electronic components if the housing is changed in such a way that its safety is influenced. This also relates to cases where the lines are damaged, there is excessive or incorrect pin assignment, connections are not assigned in the original way or similar deviations to the expected condition are determined.
- **Repairing of intrinsically safe components**
Do not introduce permanent inductive or capacitive loads into the existing circuits without ensuring that the maximum permitted voltages and amperages of the assemblies and lines are not exceeded. Intrinsically safe components are individual components that can be operated in the presence of flammable substances. The test equipment must be adjusted according to the situation-dependent conditions. Only use components which are officially approved by the manufacturer as spare parts. Unapproved components can cause a fire in the event of a leakage in the refrigerant circuit.

CTK 240 mobile air dehumidifier

- **Wiring**

Lines must be checked for the following damage:

- Damage to the insulation
- Corrosion at the contact points
- Excessive pressure on the lines
- Damage due to vibrations
- Damage due to sharp edges
- Damage due to other influences not mentioned here

Also consider the ageing of the material and continuous vibration loads due to compressors or fans when checking.

- **Identify combustible refrigerant**

Do not use any potential ignition source when searching for refrigerant leaks under any circumstance. The use of a leak detection lamp or other similar devices with a naked flame is not permitted.

1. Ensure that the components are installed correctly.
2. Ensure that sealing materials are not changed in such a way that combustible gases or objects could penetrate into the interior of the components.
3. Spare parts must correspond to the manufacturer's specifications.

NOTICE!

The use of silicones can influence the effectiveness of leak detection devices! Intrinsically safe components must not be insulated before starting work.

- **Leak detection methods**

The following leak detection methods are permitted for systems with combustible refrigerants. Electronic equipment must be used for detecting leaks. These must be selected with the sensitivity matched to the situation and recalibrated if necessary (calibration must take place in a refrigerant-free environment). The leak detection device must be adjusted to the lowest flammability limit (LFL) of the refrigerant. Liquid leakage instruments are permitted for most refrigerants. Chlorinated substances are the exception here as the chlorine in combination with the refrigerants can cause corrosion on the copper cables. If a leak is detected, all potential open ignition sources must be removed immediately. If a leak has been detected in the system which requires reworking of the piping in the form of soldering, the system must be completely free of refrigerant or, if possible, the affected part disconnected from the system using stopcocks. The affected system parts must be flushed with oxygen-free nitrogen run before and during the repair work.

- **Emptying and evacuating the system**

If the refrigerant circuit must be opened for repairs or other reasons, this must be carried out in a safe and professional way. In any event, proceed with extreme caution since ignition may occur at any time! Stick to the following procedure:

1. Drain the refrigerant
2. Flush the system with inert gas
3. Evacuate
4. Repeat steps 2 to 3 if required
5. Opening the system by cutting or soldering

The system must be flushed with oxygen-free nitrogen in order to guarantee safety. The flushing process must be repeated multiple times if necessary. Do not use compressed air or oxygen for the flushing process! After evacuating, flushing takes place by filling with dried nitrogen until the operating pressure is reached and then the system must be evacuated again. This flushing process must often be repeated until there is no more refrigerant in the system. After the last flushing, the system must be brought to the ambient pressure in order to start work. The flushing process is indispensable when soldering work is required on the piping. Ensure that the vacuum pump outlet is not near an ignition source and continuous ventilation is guaranteed.

- **Filling process**

The following requirements for the general specifications must also be fulfilled during the filling process:

- Ensure that no contamination occurs from other refrigerants (residues in the filling equipment).
- Keep the lines as short as possible to minimise the likelihood of residues forming.
- Filling bottles and cylinders must be stood upright.
- Ensure that the system is earthed before filling.
- Label the system with the refrigerant type designation after filling
- Never exceed the maximum fill level.

The system must be checked for leaks (pressure test!) before filling. The system must be checked for leaks once more after filling and before commissioning. Check for leaks again when leaving the work space.

- **Labelling when shutting down**
If a unit must be taken out of operation and the refrigerant must be disposed of, the unit must be labelled with the date and a signature. Ensure that the note remains attached to the combustible refrigerant.
- **Transportation of units which contain combustible refrigerants**
National provisions must be observed.
- **Storing of units which contain combustible refrigerant**
National provisions must be observed.
- **Transportation without the original packaging**
If the units are transported without the original packaging, they must be packed in such a way that mechanical damage is prevented. The units must be transported upright.

2.0 Guarantee

As a prerequisite for any warranty claims to be considered, it is essential that the ordering party or its representative completes and returns the "certificate of guarantee" to Climia Intakt GmbH at the time when the units are purchased and commissioned.

The guarantee conditions are listed in the "General terms and conditions of business and supply". Furthermore, only the parties to a contract can conclude special agreements beyond these conditions. In this case, contact your contractual partner in the first instance.

3.0 Intended use

The units are designed exclusively for drying and dehumidification purposes on the basis of their structural design and equipment. The units must not be used for any other purpose.

The units are only permitted to be operated by people with the relevant training and understanding of how to handle them.

Any different or additional use is a non-intended use. The manufacturer/supplier assumes no liability for damages arising from non-intended use. The user bears the sole risk in such cases.

Intended use also includes working in accordance with the operating and installation instructions and complying with the maintenance requirements.



4.0 Environmental protection and recycling

Disposing of packaging

All products are packed for transport in environmentally friendly materials. Make a valuable contribution to reducing waste and sustaining raw materials. Only dispose of packaging at approved collection points.

Disposing of the units and their components

Only recyclable materials are used in the manufacture of the units and components.

Help protect the environment by ensuring that the units or components (for example batteries) are not disposed of in household waste, but only in accordance with local regulations and in an environmentally safe manner, e.g. using authorised disposal and recycling specialists or council collection points.



5.0 Transport and packaging

The units are shipped in sturdy transport packaging. Immediately check the unit on delivery and make a note of any damage (please take photos of the damage) or missing parts on the delivery note. Inform the forwarding agent and your contractual partner.

Please retain the packaging for returns.

Claims under guarantee made at a later date will not be accepted.

6.0 Air dehumidification

The correlations occurring when air is dehumidified are based on physical laws.

These are depicted here in graphical form in order to provide you with a brief overview of the principles of air dehumidification.

Using Climia air dehumidifiers

- Even if windows and doors are well insulated, water and moisture are still capable of penetrating thick concrete walls.
- The water required for setting in the production of concrete, mortar and plaster etc. may only be diffused after 1-2 months.
- Even moisture trapped in the masonry after high-water or a flood is released very slowly.
- The same is also true of moisture contained in stored materials for example.

The moisture (water vapour) released from parts of a building or materials is absorbed by the surrounding air. As a result, the moisture content increases, which ultimately gives rise to corrosion, mould, rot, peeling of paint and other unwanted damage.

By way of example, the diagram shows the corrosion rate of metal in different levels of humidity.

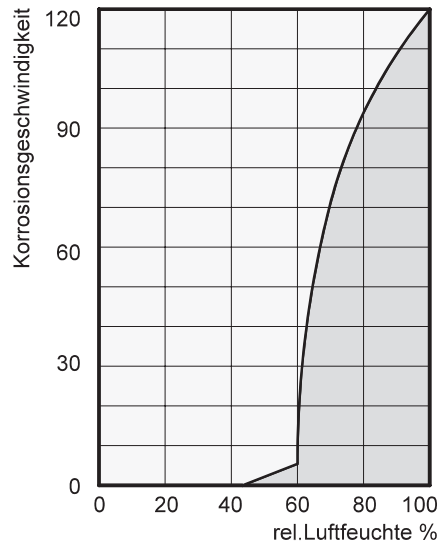

It is evident that the corrosion rate below 50% relative humidity (RH) is low, and below 40% is negligible.

The corrosion rate increases significantly above 60% RH. This threshold for damage as the result of humidity also applies to other materials, such as powdery substances, packaging, wood and electronic units.

Buildings may be dried in a variety of ways:

1. By heating and air exchange:

The air in the room is heated in order for moisture to be removed and then this air is fed outside. All of the energy that is involved is lost together with the moist air that is released.

2. By air dehumidification:

The moist air that is present within an enclosed space is continuously dehumidified according to the condensation principle.

With regard to energy consumption, air dehumidification has one distinct advantage:

Energy expenditure is limited exclusively to the air volumes present. The mechanical heat that is released by the dehumidification process is fed back into the room.

Under normal use, the air dehumidifier uses approximately 25% of the energy that is required for the "heating and ventilating" principle.

Relative air humidity

Our ambient air is a gaseous mixture which always contains a certain volume of water in the form of water vapour. This volume of water is specified in g per kg of dry air (absolute moisture content).

1m³ of air weighs approx. 1.2 kg at 20°C

Depending on the temperature, each kg of air is only capable of absorbing a certain volume of water vapour. Once this capacity has been reached, the air is referred to as "saturated" and has a relative humidity (RH) of 100 %.

Relative humidity is understood to mean the ratio between the current quantity of water vapour in the air and the maximum possible quantity of water vapour at the same temperature.

The ability of the air to absorb water vapour increases as the temperature rises. I.e. the maximum possible (absolute) water content becomes greater as the temperature rises.

Temp. °C	Water vapour content in g/m ³ at humidity of			
	40%	60%	80%	100%
-5	1.3	1.9	2.6	3.3
+10	3.8	5.6	7.5	9.4
+15	5.1	7.7	10.2	12.8
+20	6.9	10.4	13.8	17.3
+25	9.2	13.8	18.4	23.0
+30	12.9	18.2	24.3	30.3

Drying materials

Building materials and structures are capable of absorbing considerable volumes of water, such as brick 90-190 l/m³, heavy concrete 140-190 l/m³ and limestone 180-270 l/m³.

The drying of moist materials such as masonry is effected as follows:

- The moisture moves from the inside of the material to its surface

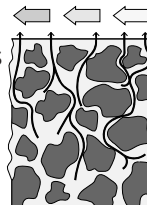

- Evaporation occurs on the surface = Transfer of water vapour to the ambient air

- The air containing water vapour is constantly circulated through the air dehumidifier. The air is dehumidified and, slightly heated, leaves the unit in order to re-absorb water vapour

- In this way, the moisture contained in the material is reduced gradually.

The material is dried!

The accumulated condensate is collected in the unit and drained off from there.

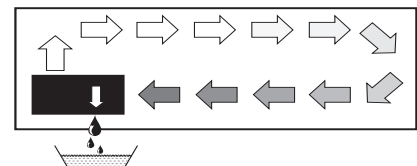

As it flows through or over the evaporator, the air stream is cooled to dew point. The water vapour condenses, and is collected in a condensate trap from where it is drained off.

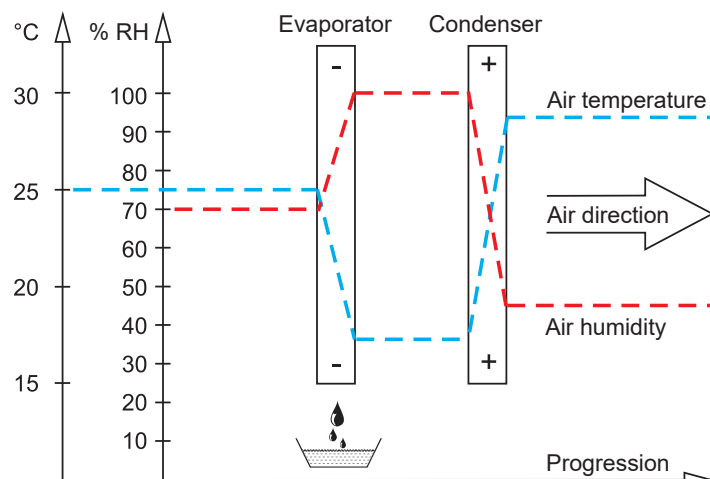

CTK 240 mobile air dehumidifier

Water vapour condensation

Because the capacity for the maximum possible volume of water vapour increases as the air is heated, the volume of water vapour contained remains constant and so relative humidity falls.

In contrast, because the capacity for the maximum possible volume of water vapour decreases as the air is cooled, the volume of water vapour contained remains constant and so relative humidity increases.

If the temperature continues to fall, the capacity for the maximum possible volume of water vapour is reduced so much so that it is ultimately equal to the volume of water vapour contained in the air. This temperature is referred to as the dew point. If the air is cooled to below the dew point, the volume of water vapour in the air will become greater than the maximum possible volume of water vapour.

At this point, the water vapour begins to precipitate.

This condenses to water and moisture is removed from the air.

Examples of condensation include steamed-up window panes in winter, or the moisture on the outside of a cold drinks bottle.



As the relative humidity of the air increases, so too does the dew point, making it easier for the temperature to fall below it.

Condensation heat

The Energy transferred to the air from the condenser consists of:

1. The amount of heat derived beforehand in the evaporator.
2. The electrical drive energy.
3. The condensation heat released by liquefying the water vapour.

Energy must be supplied when liquid is converted into a gas. This energy is designated as evaporation heat. It does not cause any increase in temperature, but is required to convert a liquid into a gas. Conversely, energy is released when gas is liquefied, this is designated as condensation heat.

The amount of energy from evaporation heat and condensation heat is the same.

**For water, this is:
2250 kJ/kg (4.18 kJ = 1kcal)**

From this it is evident that the condensation of water vapour causes a large quantity of energy to be released.

If the moisture that it is to be condensed is not introduced by evaporation in the room itself, but from outside, e.g. through ventilation, the condensation heat released contributes to the heating of the room. With drying operations, a heat cycle is created, whereby heat is consumed for evaporation and released for condensation. When dehumidifying fed air, a larger contribution of heat is created, which manifests itself as a temperature increase.

Generally speaking, the time required for the drying process is not only dependent on the output of the unit, but is determined to a greater extent by the speed at which the material or building section loses its moisture.

7.0 Unit description

The units have been designed for universal and straightforward air dehumidification.

Their compact dimensions allow the unit to be transported and set up with ease.

The units operate in accordance with the condensation principle and are equipped with a hermetically sealed refrigerant system, automatic defrosting, low-noise and low-maintenance fan and connection cable with plug.

The fully automatic control, the variable hygostat, the condensate container with integrated overflow protection and the connection nozzle for condensate drainage guarantee fault-free continuous operation.

The units conform to the fundamental health and safety requirements of the appropriate EU stipulations.

The units are dependable and offer ease of operation.

The units are used in all locations, where dry air is a must and where economic consequential damage (such as that caused by mould) must be prevented.

The units may be used for the drying and dehumidification of areas such as:

- Living rooms, bedrooms, shower rooms or cellar rooms
- Weekend homes, caravans
- Warehouses, archives, laboratories
- Bathrooms, wash rooms and changing rooms etc.
- Basements, storage rooms

Operating sequence

The units are switched on and off by the power key.

In dehumidification mode, one of

the "Fan stage" indicator lights on the control panel illuminates.

The fan extracts the moist room air through the intake grill with filter, evaporator and the condenser behind.

Heat is removed from the room air on the cold *evaporator*. The air is then cooled to below dew point. The water vapour contained in the room air is then deposited as condensate or rime on the evaporator fins.

On the *condenser* (heat exchanger), the cold and dehumidified air is warmed up again and discharged back into the room via the outlet grill with a temperature increase of around 5 - 10 °C above the room temperature.

The processed, dry air then re-mixes with the room air.

Continuous circulation of the room air through the unit gradually reduces the relative humidity (% RH) in the room to the desired humidity level.

Depending on the room air temperature and the relative humidity, condensed water will drip into the condensate trap and then through the integrated discharge nozzle into the condensate

container below either continuously or only during the defrosting phases.

A float is installed inside the condensate container. In the event that the container is full, the float will activate a microswitch which will switch off dehumidification mode.

The units switch off and the "container full" indicator light on the control panel illuminates. This extinguishes again when the empty condensate container is re-inserted.

The units then restart.

In unattended continuous operation with an external condensate connection, the condensate that occurs is drained continuously via a hose connection. The units then start.

In unattended continuous operation with an external condensate connection, the condensate that occurs is drained continuously via a hose connection.

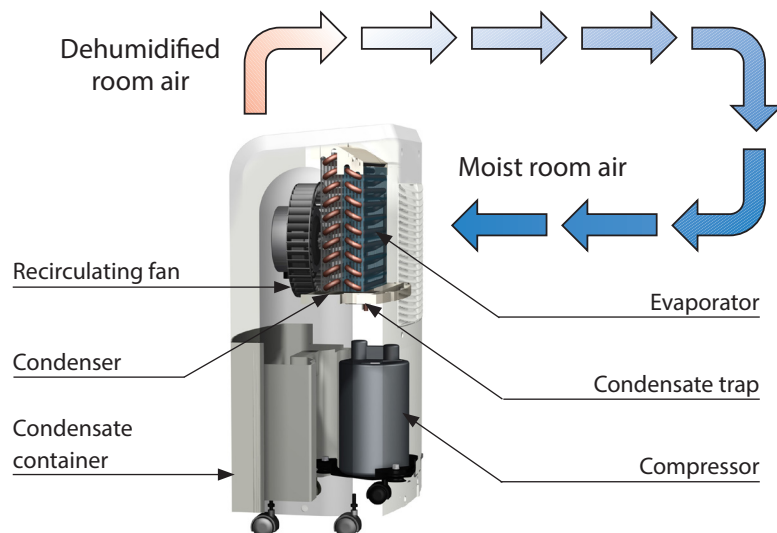

Fig. 1 Schematic depiction of the workings of the air dehumidifier

CTK 240 mobile air dehumidifier

8.0 Set-up

For the best economic and safe use of the units, the following notes must be followed in full:

- The units must be set up in an upright and level position, to ensure that the condensate can drain freely
- To ensure optimum air circulation, the units should be set up in the centre of the room, where possible
- Ensure that the room air can be sucked in and discharged without hindrances
- Observe a minimum clearance of 50 cm from walls at all times
- Units must never be set up in the immediate vicinity of heaters or other sources of heat
- Air circulation is improved if the unit is set up approx. 1 m above the ground
- The room being dried or dehumidified must be closed to the surrounding atmosphere
- Avoid having opened windows and doors etc., and avoid frequent entry to or exit from the room as much as possible
- The units may not be used in environments containing a great deal of dust or chlorine, or in places with atmospheres containing ammonia
- The output of the unit is entirely dependent on the conditions inside the room, room temperature, relative humidity and observance of the set-up instructions



Fig. 2 Schematic depiction of how to set up the air dehumidifier

9.0 Commissioning

Before commissioning the unit or if local requirements dictate, the air-inlet grill and air-outlet grill must be checked for contamination.

NOTE

A contaminated grille or filter must be cleaned or replaced immediately.

Important notes prior to commissioning

- All extensions to the electrical connection must be of a sufficient cable size and must only be used fully rolled out or unrolled
- Never use the power supply connection cable as a pull cord
- After being switched on, the units operate fully-automatically until switched off by the hygrostat or float when the condensate container is full
- The condensate container must be inserted properly
The unit cannot be operated if the condensate container is not inserted properly!
- In order to prevent damage to the condenser, the units are equipped with a mechanism that prevents the compressor being immediately switched back on after it is switched off
The units do not switch back on until a waiting time of around 3 minutes has elapsed!
- If the units work in continuous operation with an external condensate drainage connection, refer to the relevant section

Control panel

The control panel contains various keys, indicator lights and a display.

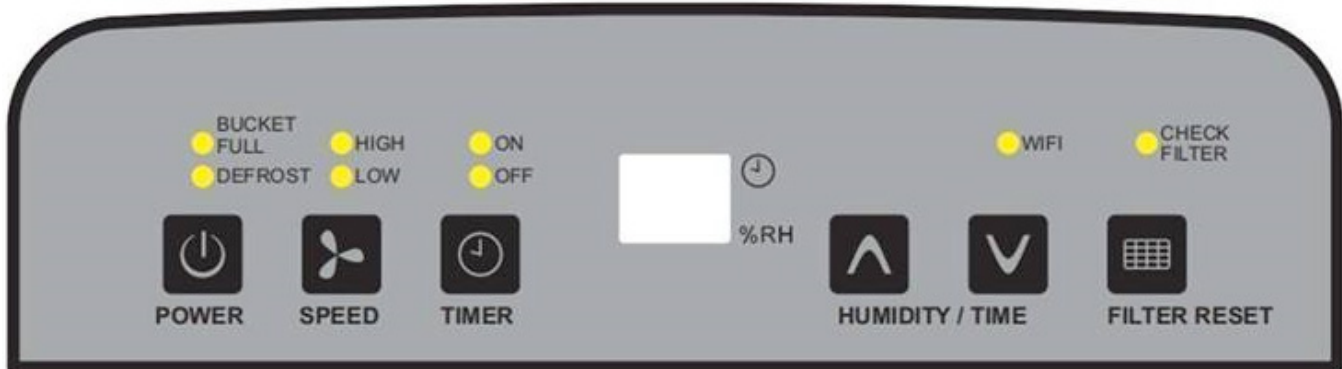

1. The power key switches the unit on and off.

2. The speed key sets the fan stage. The min/max fan stage indicator lights indicate the fan stage at which the unit is running.

3. If required, the unit can be switched to manual timer mode using the timer key.

4. Use the "Humidity/Time" arrow keys to set the required air humidity in the installation room or the required air humidifier operating time.

5. After an operating time of 250 hours, the "Check Filter" indicator light illuminates and the filter must be removed and cleaned according to the instructions. The unit can be reset using the filter reset key after inserting the filter.

6. The display shows the current air humidity or the required air humidity during regulation, or the required operating time. The display shows the current air humidity again 10 seconds after the setting is made.

7. The bucket full indicator light indicates when the condensate

bucket is full and must be emptied.

8. The unit is in defrost mode while the "Defrost" operating light is illuminated.

9. Refer to the „Wi-Fi“ chapter for information on the Wi-Fi indicator light.

NOTE

*In room temperatures below **10°C** and relative humidity below **40%**, economical use of the unit can no longer be guaranteed.*

Commissioning the units

1. Connect the unit's electrical connection to a properly installed mains socket.

2. Press the power key once to switch on the unit.

3. Use the arrow keys to set the required air humidity of the installation room. The air humidity can be set at increments of 5 %.

The recommended approximate setting values are listed in the adjacent section.

NOTE

After setting the required air humidity, the display shows this for another 10 seconds before displaying the current air humidity again.

NOTE

Note that the compressor does not switch on until a waiting time of 3 minutes has elapsed.
Restart protection!

Adjusting units/moisture

The unit's dehumidification power is entirely dependent on the conditions inside the room, the room temperature, the relative humidity and observance of the notes in the "Setting up" chapter.

The higher the room temperature and relative air humidity, the higher the dehumidification power.

A relative humidity of around 45 to 60 % is sufficient in living rooms. The air humidity should not exceed 40 to 45 % in warehouses, archives, etc.

CTK 240 mobile air dehumidifier

Timer function

The units feature an integrated timer function. A delay time can be set for a switched off unit (attached electrical connection without pressing the power button). To do this, first press the timer key and the desired time can be set via the arrow keys.

The unit will switch itself on automatically after the set time has elapsed.

Pressing the timer key switches the unit's automatic mode on and off.

If automatic mode is switched off, the arrow keys can be used to set the required operating time.

The unit will switch itself off automatically after the set time has elapsed.

Both the switch-on time and the operating time can be set for a maximum of 24 hours in increments of one hour.

NOTE

The devices can be switched ON and OFF via an external timer or a Smart Home socket if required.

NOTE

For economical and technical reasons, the units must not be operated at an ambient temperature below 5 °C.

The following notes must also be observed in full:

- Ensure that the air can discharge without hindrances

This is the only way to guarantee optimum unit operation!

- Ensure that sensitive objects such as house plants are not placed directly in the air flow emerging from the unit.

Automatic defrost system

The moisture contained in the room air condenses when cooling and coats the evaporator fins with rime or ice depending on the air temperature and the relative humidity (% RH).

The automatic defrost system that is integrated in the unit switches the defrost cycle on if required.

The rime or ice that has accumulated on the exchanger surfaces is defrosted using electronic circulation mode as required.

This tried and tested defrosting method guarantees high dehumidification performance.

Dehumidification mode is paused during the defrost phase. The "Defrost mode" indicator light indicates that the defrost cycle is running.

NOTE

If the room temperature is sufficiently high (>12 °C), the surface of the fins will not be cold enough for rime formation to occur, rendering defrosting unnecessary. Therefore, the air dehumidifier works economically.

Emptying the condensate container

The integrated condensate container must be emptied from time to time.

Dehumidification mode is switched off if the condensate container is full.

The "BUCKET FULL" indicator light indicates that the unit has switched off.

1. Pull the full container forwards and out carefully.



2. Pour the water into a drain.

NOTE

After being emptied, the condensate container incl. float must be checked for damage, contamination etc.

3. Re-insert the emptied container carefully into the unit.

The "BUCKET FULL" indicator light extinguishes and the unit continues to run automatically.

NOTE

The unit can only be started once the condensate container has been inserted correctly.

Continuous operation with external condensate outlet

The units are equipped with a special connection nozzle on the rear.

A special drainage hose that is supplied can be connected here.

CAUTION!

There is no unit overflow protection in this variant.

1. The condensate hose connection must be switched off first for this purpose. The rubber stopper can then be removed.
2. Pull the condensate hose connection over drain hose.
3. Connect the drain hose to the connection nozzles and tighten the condensate hose connection by hand.



mode, the condensate should preferably be drained into a lower-level drain.

If using an external collection container (pan, bucket, etc.), the unit must be placed at a correct height.

CAUTION!

Ensure that the drainage hose is placed at an incline to the drain to allow the condensate to drain without hindrance!

10.0 Shutdown

Press the power key once to switch on the unit.

If the units are inactive for long periods, disconnect them from the mains power supply.

Empty the condensate container completely and dry with a clean cloth.

Beware of dripping condensate!

The units must be cleaned and dried completely before storing.

When storing the unit, cover with a plastic sheet/foil if necessary and store in an upright position in a sheltered and dry location.

The units are only permitted to be stored upright in a suitable storage location that is protected against dust and direct sunlight.

11.0 Unit transport

The units are equipped with four foot rollers and two additional handles for easy and convenient transport.



- Before each change of location, switch off the unit and remove the power plug from the mains socket
- Empty the condensate bucket completely.

NOTE

Beware of dripping condensate. After switching off the units, the evaporator may continue to defrost under the influence of the ambient temperature.

- If residual moisture remains on the evaporator or water remains in the condensate container, the units must only be transported in an upright position
- The transport rollers are only suitable for use on level and smooth ground
- The units must be carried when transporting on rough terrain or uneven surfaces

CAUTION!

The mains cable must never be used as a pull cord or fixing device.

CTK 240 mobile air dehumidifier

12.0 Care and maintenance

NOTE

Regular care and maintenance is fundamental to a long service life and fault-free operation of the unit.

All moving parts have a low-maintenance permanent coat of lubricant. The entire refrigerant system is designed as a maintenance-free, hermetically sealed system and may only be repaired by a specialist.

CAUTION!

Before undertaking any work on the units, the power plug must be removed from the mains socket.

- Observe the regular care and maintenance intervals
- In accordance with the operating conditions, the units must be checked as required but at least yearly by a specialist to ensure that they are in a condition that is safe to use
- Only clean the units with a dry or damp cloth
Do not use a water jet!
- Never use abrasive or solvent-based cleaners
- Even with heavy contamination, use only suitable cleaners
- Check the inlet and outlet grille for contamination on a regular basis
Clean or replace if required!

Cleaning the condenser and evaporator

The unit housing must be opened to allow the inside of the unit to be cleaned and to provide access to electrical components.

NOTE

Adjustment and maintenance work may only be carried out by authorised and qualified technicians.

- Clean the condenser and the evaporator by blowing, vacuuming or using a soft brush.

Do not use water jets!

NOTE

When cleaning the exchanger, particular care must be taken because the fine aluminium fins bend very easily.

- Clean the interior surfaces on the units, the condensate traps with hose connection, the fan and the fan housing carefully
- Check all unit components for damage and repair if necessary
- Carefully refit all parts that were removed in reverse order

CAUTION!

An electrical safety check must be carried out in accordance with VDE 0701 after any work on the units.

Filter cleaning

To prevent damage to the unit, it is equipped with an intake grill with integrated air filter.

In order to prevent power losses or unit faults, the intake grill with filter must be inspected as required, but every 2 weeks at the latest, and cleaned if necessary.

1. Use the "POWER" key to switch the unit off.
2. Remove the power plug from the mains socket.
3. Reach into the recessed grip and remove the air filter.



CAUTION!

The unit is not permitted to be operated without the air filter fitted!

4. Clean the air filter with lukewarm water or a vacuum cleaner.

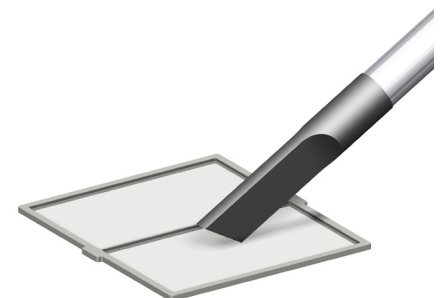

CLIMIA

5. Heavier contamination may be remedied by rinsing the filter in a lukewarm (max. 40°C) soap solution.
Finally, always rinse the filter carefully with clear water and allow to dry!



6. Also check the intake grill for contamination and clean if necessary.
7. Before refitting grill and filter, ensure that they are fully dry and that no damage has been sustained.

NOTE

Heavily contaminated or damaged air filters must be replaced with new parts. Only original spare parts may be used.

13.0 Troubleshooting

The units are manufactured using state-of-the-art production methods and tested several times to verify their correct function.

However, if a functional fault should occur, the unit should first be checked in accordance with the following list.

NOTE

Adjustment and maintenance work may only be carried out by authorised and qualified technicians.

The unit does not start:

- Check the hygostat's setting
The set value must be lower than the relative humidity in the installation room!
- Check the power supply and the power fuse provided by the customer 230V/1~/50 Hz
- Check the power plug and the cable for damage
- Check the condensate bucket's fill level and seating
The "Bucket full" indicator light must not be illuminated!
- Check that the microswitch [MS] on the condensate bucket is functioning
- Check that the inlet and outlet are free *Overheating!*
- Check the fuse on the control board

The unit runs but condensate is not formed:

- Check the room temperature.
The operating range of the unit is between 5 °C and 32°C
- Check the air humidity
min. 30 % RH required
- Check the intake grill and air filter for contamination
Clean or replace if required!
- Have the heat exchanger fins checked for contamination
This work requires the unit to be opened and must therefore only be carried out by an authorised specialist company!

The unit is loud or condensate runs out:

- Check whether the unit is on a stable and even base
- Check whether the unit is standing upright and stably
- Have the condensate trap or the connection nozzles checked to see whether there are dirt deposits on them
This work requires the unit to be opened and must therefore only be carried out by an authorised specialist company!

CAUTION!

Work on the refrigerant system and on the electrical equipment must only be conducted by a specially authorised specialist!

NOTE

The units work with environmentally-friendly and ozone-neutral R134a refrigerant. The mixture of refrigerant and oil within the unit must be disposed of properly in accordance with the statutory or locally-applicable regulations.

NOTE

If the unit fails to function correctly after the checks have been carried out, contact an authorised specialist.

CTK 240 mobile air dehumidifier

14.0 Electrical wiring

- The units are operated with 230 V / 50 Hz alternating current
- The electrical connection is established using a built-in mains cable with earthed safety plug
- Extensions to the connection cable may only be carried out by authorised electricians, subject to the length of the cable, connected load of the unit and taking into consideration how the unit is used at its location

NOTE
*The electrical connection to the units must be made at feedpoints with residual current devices in accordance with VDE 0100, Section 704.
 When installing the units in extremely damp environments such as laundry rooms, showers etc., the unit must be secured with a residual current device provided by the customer in accordance with the regulations.*

CAUTION!
All cable extensions must only be used in fully unreeled or reeled off condition.

15.0 Electrical wiring diagram

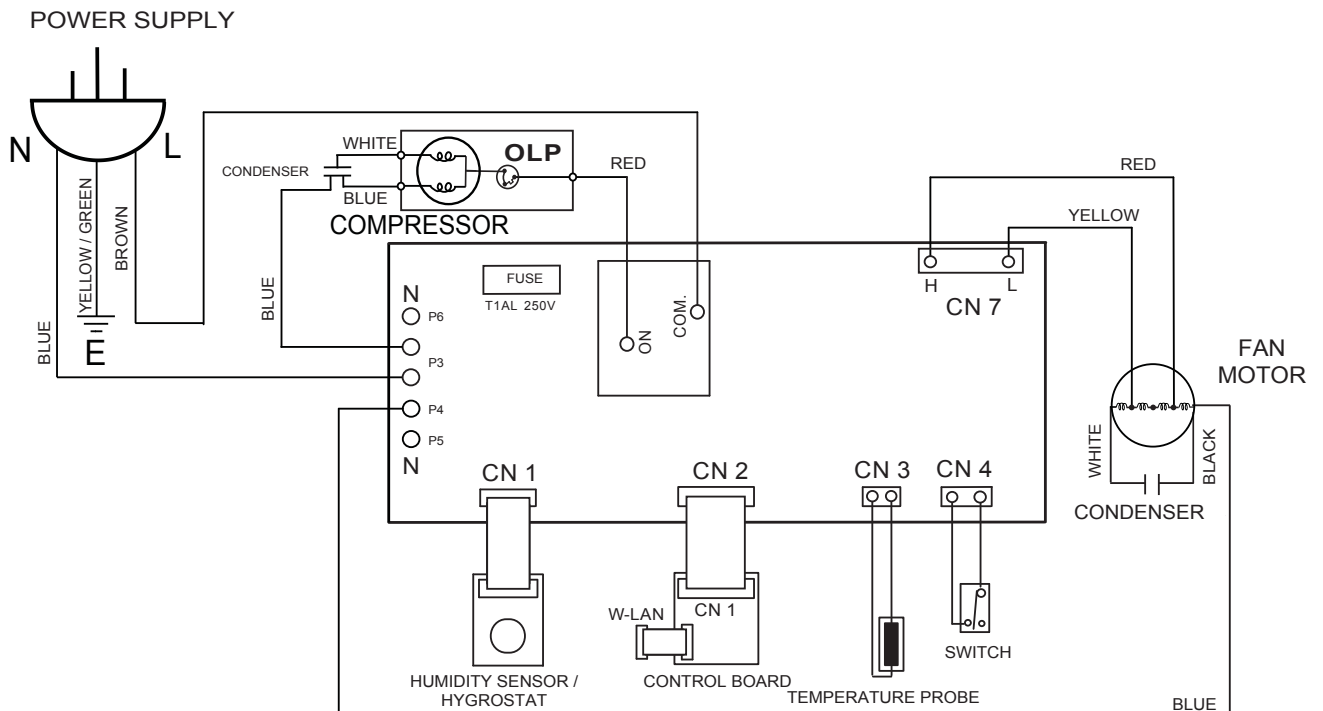

CLIMIA

16.0 WiFi function

The unit can also be conveniently controlled remotely via app. To do so, use the "SmartLife" app from the Apple App Store or the Google PlayStore

To download the SmartLife app, simply scan the following QR code or search directly in the AppStore. To set it up, follow the instructions in the app.



The Wi-Fi indicator light shows the current status of the unit. The light runs through states 1-5 during a new set-up.

After the unit has been successfully connected, it can be controlled via the app. All unit functions are available in the app:

There are two ways to disconnect the unit from the connected router:

1. Remove the unit via the SmartLife app.
2. Press the power button for at least 5 seconds..

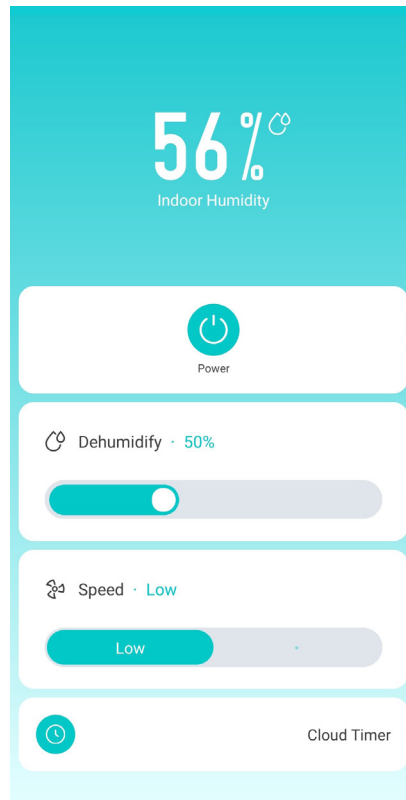

State	Description	LED
1	Pairing - Configuration	Rapid flashing (250 ms)
2	Pairing - AP	Slow flashing (1500 ms)
3	Pairing successful but no connection to the router	Off
4	Pairing successful and connected to the router	On
5	Successful connection to the app	On
6	WiFi in standby mode	Off

CTK 240 mobile air dehumidifier

17.0 General view of unit

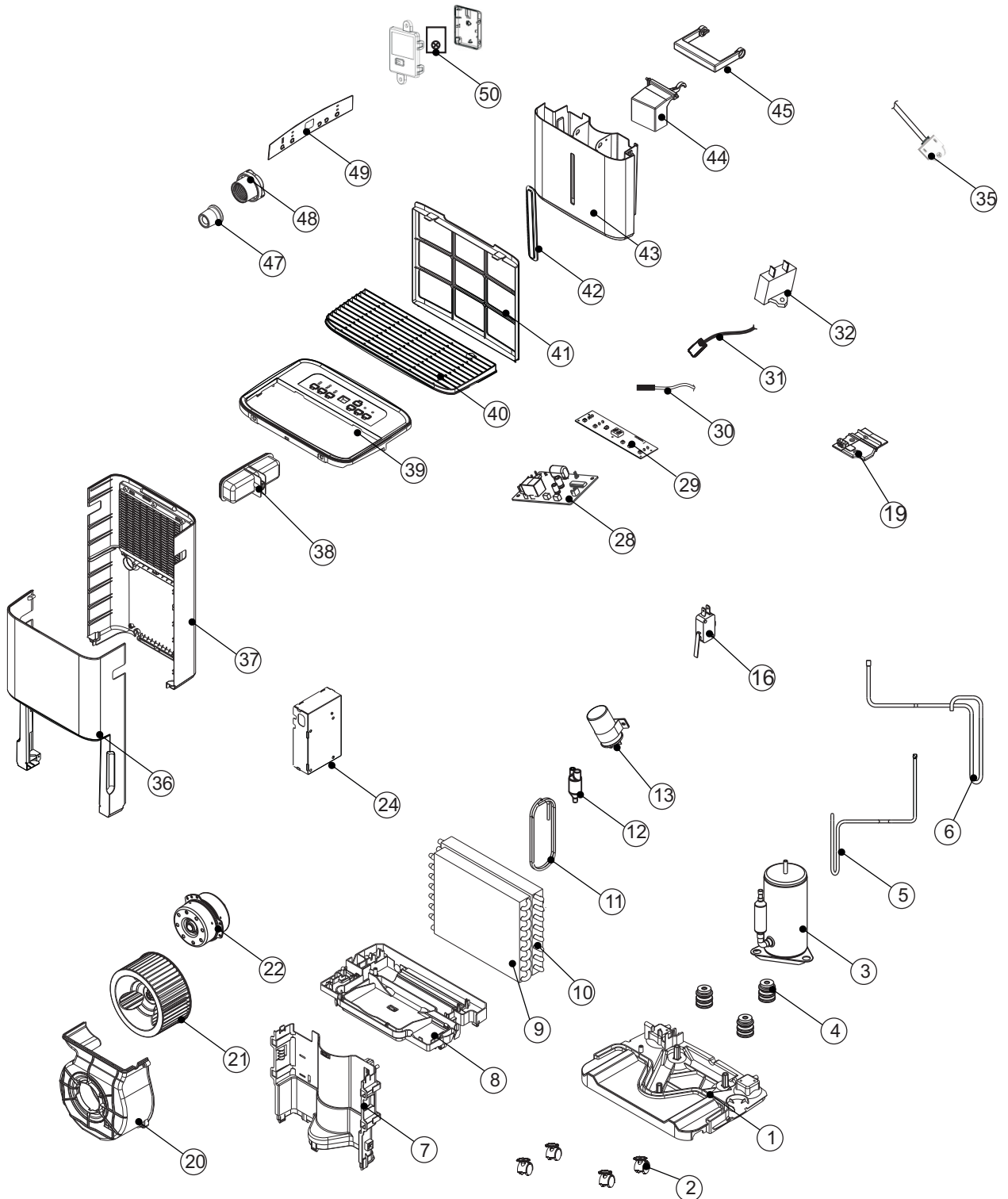

We reserve the right to modify the dimensions and design as part of the ongoing technical development process.

18.0 Spare parts list

No.	Designation	EDP no.
1	Floor pan	
2	Conveyor rollers	
3	Compressor, cpl.	
4	Vibration dampers	
5	Suction pipe	
6	Drain line	
7	Centre wall	
8	Condensate trap	
9	Evaporator, complete.	
10	Condenser, complete.	
11	Capillary	
12	Y-pipe	
13	Condenser, (for compressor), complete)	
16	Microswitch	
19	Condensate trap cover	
20	Fan housing	
21	Fan wheel	
22	Fan motor	
24	Distribution block	
28	Control board	
29	Conductor board / board	
30	Probe (evaporator/EVAP)	
31	Hygrostat	
32	Condenser (fan motor)	
35	Mains cable with plug	
36	Front wall	
37	Back wall	
38	Transport handle	
39	Top cover	
40	Intake grill	
41	Air filter	
42	Condensate bucket cover	
43	Condensate container	
44	Float, cpl.	
45	Transport handle (condensate bucket)	
47	Rubber stopper	
48	Condensate hose connection	
49	Control panel	
50	Bluetooth board	

When ordering spare parts, please always state the EDP no. and unit number (see name plate)!

CTK 240 mobile air dehumidifier

19.0 Technical data

Series		CTK 240
Operating range, temperature	°C	5 to 32
Operating range, humidity	% RH	30 to 90
Dehumidification capacity max.	l/day	30
At 27 °C/60 % RH	l/day	18
Fan stages		2
Max. airflow volume	m ³ /h	240/186
Condensate container capacity	Litres	6.3
Refrigerant ¹⁾	---	R134A
Refrigerant quantity	g	200
Power supply	V/~ /Hz	230/1/50
Max. rated current consumption	A	4.1
Max. power consumption	kW	0.57
Sound pressure level L _{pA} 1m ²⁾	dB (A)	46/41
Transmission frequency WiFi module	GHz	2,4000-2,4835
Transmit power max, WiFi module	dBm	18
Dimensions		
Depth	mm	272
Width	mm	384
Height	mm	610
Weight	kg	17

¹⁾ Contains greenhouse gas according to Kyoto protocol

²⁾ Noise level measurement DIN 45635 - 01 - KL 3



20.0 Maintenance log

Unit type: **Unit number:**

	1	2	3	4	5	6	7	8	9	10	11	12	13	14	15	16	17	18	19	20
Unit cleaned - outside -																				
Unit cleaned - inside -																				
Fan blade cleaned																				
Fan housing cleaned																				
Condenser cleaned																				
Evaporator cleaned																				
Fan function checked																				
Air-inlet grid with filter cleaned																				
Unit checked for damage																				
Safety devices checked																				
All fastening screws checked																				
Electrical safety check																				
Test run																				

Comments:

.....

.....

1. Date: Signature	2. Date: Signature	3. Date: Signature	4. Date: Signature	5. Date: Signature
6. Date: Signature	7. Date: Signature	8. Date: Signature	9. Date: Signature	10. Date: Signature
11. Date: Signature	12. Date: Signature	13. Date: Signature	14. Date: Signature	15. Date: Signature
16. Date: Signature	17. Date: Signature	18. Date: Signature	19. Date: Signature	20. Date: Signature

Unit to be maintained only by authorised specialists in accordance with the statutory regulations.

EC – Declaration of Conformity

Original Declaration of Conformity



We do hereby declare that the units named below, produced and sold by us, satisfy the relevant basic requirements of the EC Directives, the EC safety standards and other product-specific EC standards.

Name of Manufacturer: **Intakt GmbH**
Climia - Air conditioning and heating technology
Niemeierstraße 13
D - 32758 Detmold, Germany

Name of the CE representative: **Intakt GmbH**
Climia - Air conditioning and heating technology
Niemeierstraße 13
D - 32758 Detmold, Germany

Unit (machinery) model: Air dehumidifier

Series / Class: CLIMIA CTK 240
Series / Class Number: 1803...

Delegated regulations (EU): 2011/65/EU:2011
2014/30/EU:2014
2014/35/EU:2014
2014/53/EU:2014

Applicable standards: DIN EN 12102-1:2018
DIN EN 55014-1:2017; DIN EN 55014-2:2015
DIN EN 60335-1:2012; DIN EN 60335-2-40:2014
DIN EN 61000-3-2:2015; DIN EN 61000-3-3:2014
DIN EN 62233:2008

Detmold, 19th June 2018

Intakt GmbH

.....
Managing Director's signature

Intakt GmbH
Climia - Klima- und Wärmetechnik
Niemeierstraße 13
D - 32758 Detmold